

Multistage Water Treatment System



Instruction Manual

- Be sure to read through this manual for proper use and safety.
- You must be familiar with the Safety Instructions before using this product.
- Please keep the user's guide where it is easily accessible.
- This product is designed for in-home use.
- Design and product development may be upgraded without a public notice.

CONTENTS

Safety Instructions

Flow of Water	3
Power Connection	4
Installation	5
During Use	5

Introduction

Checking Components	6
Names of Components	7-8

Installation and Operation

Installation	9-10
Operation	10-11
Understanding the LED Display Indicators	12

Maintenance

Exchange Filters and Mineralizer Unit	13
Exchange UV Unit	14

Service and Specifications

Before Requesting Service	15
Product Warranty	15
Product Specifications	16

SAFETY INSTRUCTIONS

Congratulations on the purchase of your new FrescaPure™ Ultra Multistage Water Treatment System.

This product provides filtered, enriched and cleaner water through multiple stages.

Do not use with water that is microbiologically unsafe or of unknown quality without adequate disinfection before or after the System.

For use on cold potable water supplies only.

» Flow of Water

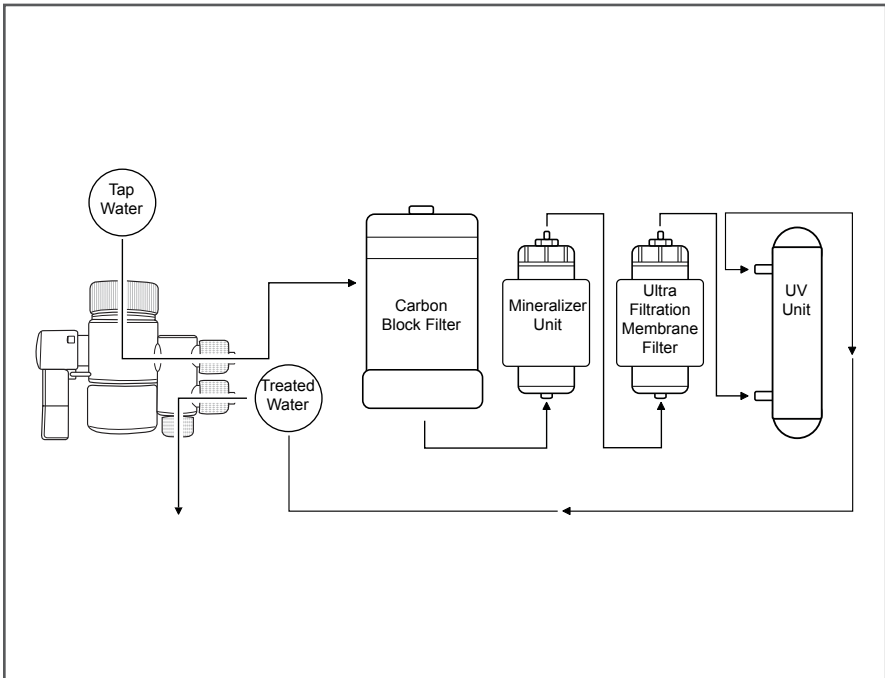

SAFETY INSTRUCTIONS

Follow the instructions below to use the product safely and properly. To avoid personal injury or property damage, please read them before use.

POWER CONNECTION

Warning

Do not modify the power cord in any way.
It can cause an electric shock or fire.

Be sure to use the provided adapter only.
It can cause an electric shock or fire.

Do not insert or pull out the power plug with wet hands.
It can cause an electric shock or fire.

If water leaks, disconnect the power cord from the wall outlet, and dry completely.
It can cause an electric shock or fire.

Before product cleaning or filter/unit exchange, be sure to remove the power plug from the outlet.
It can cause an electric shock or fire.

INSTALLATION

Warning

Installation of this product must comply with all state and local laws and regulations. Refer to your local agencies for details.

Do not install the product in an area where the temperature can drop below 32° F.

Do not install the product near heat-generating equipment. It can cause a fire.

Do not install the product in a place that contains a lot of moisture (bathroom, swimming pool, etc.) or water (or raindrops) are present, or in a dusty place.

INSTALLATION

Caution

Do not cut or modify the dual tube set. It is an exclusive hose.

DURING USE

Caution

Clean the surface of the product with a soft cloth.

Replace filters/units according to the respective exchange cycle.

When you continuously use the expired filters/units, filtration quality may decrease.

Exchange cycles for filters and units

- **Carbon block filter: 1000 gallons**
- **Mineralizer unit: 1000 gallons**
- **UF Membrane filter: 1000 gallons**
- **UV Unit: approximately 2000 hours**

INTRODUCTION

Checking Components

Please make sure the following components are included in the package.

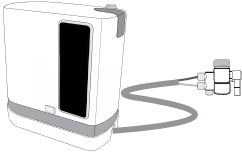

Filtration Unit



Power Adapter

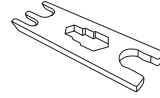

Multi-Purpose Spanner



Faucet Adapters
(3 types)



Rubber Washers
(4 EA)

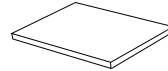

User Guide



Valve Adapters (Clips)
(3 EA)



Tube Ties
(3 EA)



Screws
(3 EA)

- Four rubber washers are included and may be necessary for installation. Choose an appropriate type of rubber washer, connect it to the valve adapter, and finally connect it to the diverter valve.
- For more details, see “Installation” on page 9.
- Clips, screws, and tube ties are used to fix the dual tube set (hoses) on the wall.

Names of Components

The FrescaPure™ Ultra Multistage Water Treatment System consists of the following components and their names and roles are as follows. Familiarize yourself with these before reading the operation details.

Components

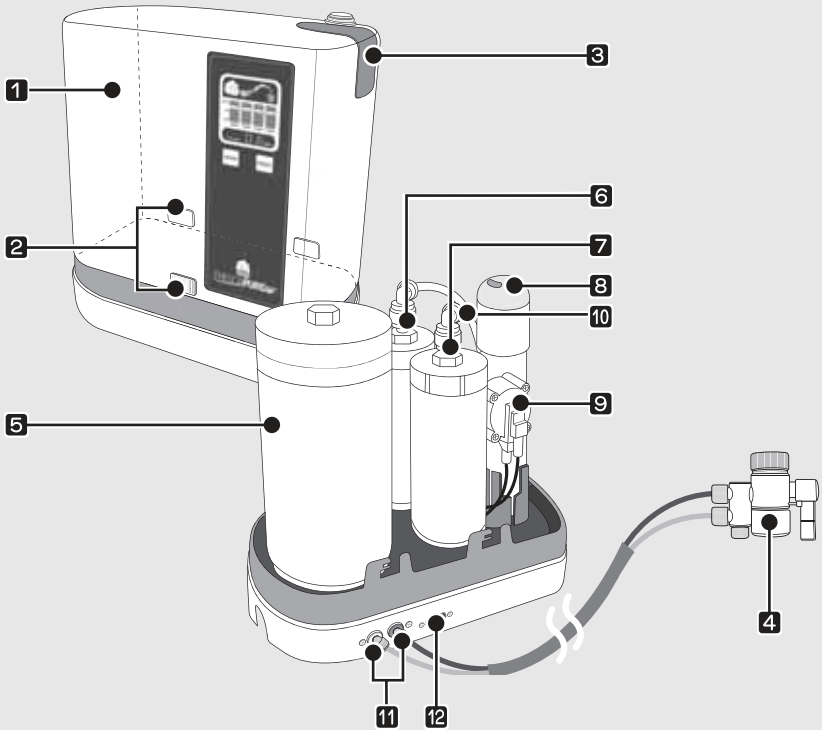

INTRODUCTION

Names of Components

1. Cover

2. Lock (Joint Clip)

Use these joint clips (1 EA: front, 2 EA: rear) to open or close the cover. When the cover is properly located, to open the cover, press the joint clip to the left. If you press it to the right, the cover is closed.

3. UV Unit Viewing Window

You can see the operation of the UV Unit. *If the lamp is not working or it is not turned on, replace the unit.*

4. Diverter Valve

Close this valve when you are not using the product. Open this valve when you want filtered, enriched and cleaner water. Each time you use the unit, let the water flow for a few seconds before filling your glass. The upper hose supplies the tap water into the system. The filtered water comes out from the lower hose.

- *For more details, refer to “Operation” on page 10.*

5. Carbon Block Filter

6. Mineralizer Unit

7. UF membrane (Hollow fiber membrane) filter

8. UV Unit

9. Pressure Switch

10. Flow Meter

11. 2-Way Bulkhead Set

Blue: Treated water outlet

White: Tap water inlet

12. PowerPort

Installation

To install the product, follow the procedure below:

1. Remove the plug on the 2-way bulkhead set.
 - Remove the plug by using the multi-purpose spanner.

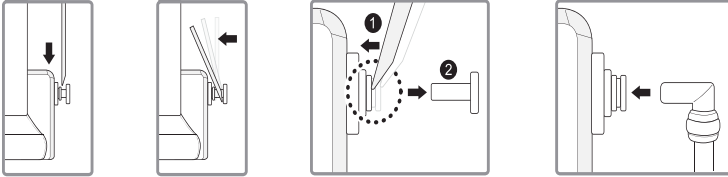

2. Connect the dual tube set to the body of the product.
 - Connect the white part of the 2-way bulkhead to the white tube and the blue part to the blue tube. (If the colors are incorrectly connected between the dual tube set, the flow of water is decreased and may cause filter damage). Please be cautious when installing them.

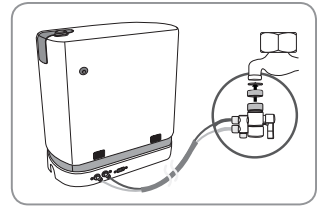

3. Connect the diverter valve to the tap.
 - If there is an aerator (a screen-type nozzle) on the end of your faucet, unscrew and remove it.
 - Place the diverter valve on the end of the faucet. Use the supplied faucet adapter if necessary to provide a good fit.
 - Turn the textured collar ring counterclockwise until the diverter draws up tightly against the faucet.
 - Use the tube ties to secure the tubes to the faucet.

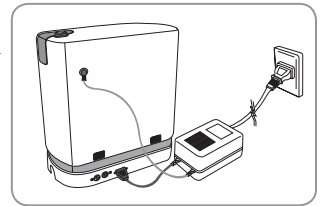

4. Connect the power adapter to the body of the product and plug it in the outlet.
5. Flush the system by letting the water run through the whole system for five minutes.
6. Installation is complete.

INSTALLATION AND OPERATION

Under-Counter Installation

The FrescaPure Ultra™ System can also be installed under your kitchen's counter. Please contact your local Distributor to purchase the installation kit. The instructions are included with the kit.

Operation

The FrescaPure™ Ultra provides filtered, enriched and cleaner water through multiple treatment stages. When powered, the UV Unit provides an additional treatment stage by reducing normally occurring non-pathogenic nuisance microorganisms.

After installation is completed, operate the product as follows:

1. Using this water system.

The diverter valve on this water system allows you to select between treated water and ordinary tap water.

Use cold water only, not warm or hot.

For ordinary tap water, simply turn on the tap. (Handle on diverter valve should be vertical).

For treated water, turn on the cold tap water and turn the handle on the diverter valve.

Treated water will continue to flow until the tap is shut off.

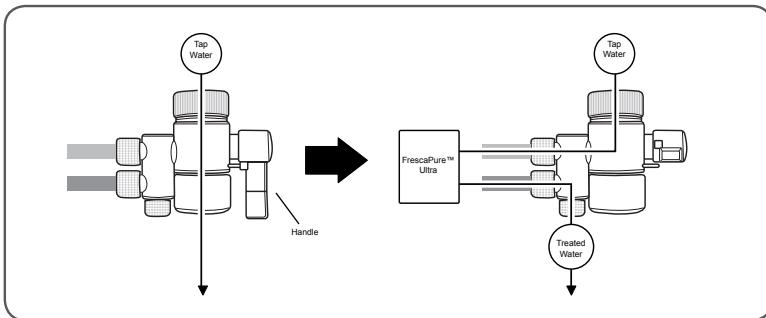

Operation

2. The water flows through multiple stages via hydraulic pressure.
3. The first time you use the system, please flush it by letting the water run through the whole system for five minutes*.

Caution: If the product is not connected to the power, neither the UV Unit nor the LED display will work. In that case, the water goes through the two filters and the Mineralizer Unit, but is not treated by the UV Unit.

4. When the water source is shut off, the water trapped in the system flows out to depressurize it. Then, the water sensor is turned off and the UV Unit turns off.

* Note: Each time you use the system, let the water flow for a few seconds before filling your glass.

INSTALLATION AND OPERATION

Understanding the LED Display Indicators

The Display Indicators will show when the system is on, display the efficiency of each filtration, mineralization and UV stage and indicate when it is time to exchange the Filters, Mineralizer Unit or the UV Unit.

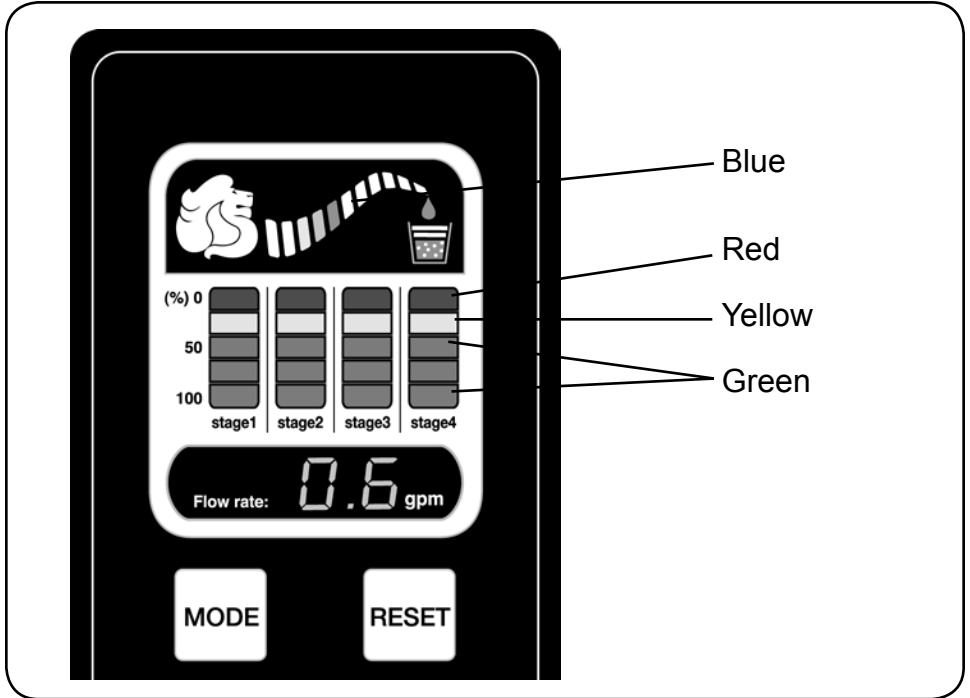

STAGE 1 - Carbon Block Filter (**WF0650**).

STAGE 2 - Mineralizer Unit (**WF0651**).

STAGE 3 - UF Membrane Filter (**WF0652**).

STAGE 4 - UV Unit (**WF0653**).

BLUE Indicates that the system is on and working.

GREEN Indicates when filtration, mineralization and UV Unit are working effectively.

YELLOW Indicates that it is time to re-order a filter, a Mineralizer Unit or UV Unit.

RED Indicates that it is time to exchange a filter, a Mineralizer Unit or UV Unit.

Exchange Filters and Mineralizer Unit

The exchange cycles of the Carbon Block Filter, Mineralizer Unit, and UF Membrane Filter are: 1000 gallons. The exchange cycle may differ depending on the water source and operation.

In order to exchange filters or unit, follow the procedure below.

1. Disconnect the power.

2. Press the joint clips (1 EA: front, 2 EA: rear) to the OPEN position.

3. Lift the cover off the product.

4. Remove the desired filter or unit.

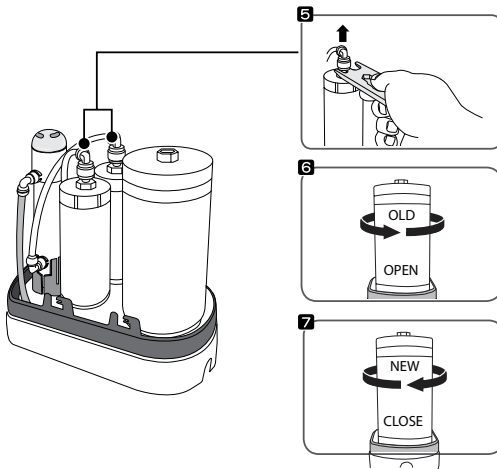

8. To insert the new filter or unit, follow the reverse order of the filter or unit removal procedure.

9. After exchange is complete, close the cover of the product and press three joint clips to the CLOSE position.

10. Connect the power.

11. **Reset the LED Display Indicator.** Use the Mode Button to select the Filter or Unit that was replaced. Press and hold the Reset Button for 3 seconds to reset the status of the new Filter or Unit to 100%.

12. Flush the system by letting the water run through the whole system for five minutes.

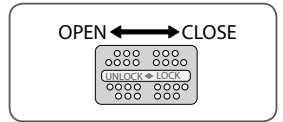
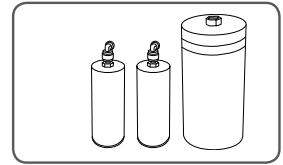

Exchange the UV Unit

The exchange cycle of the UV Unit is approximately 2,000 hours.

If the unit does not light, exchange it as follows:

1. Disconnect the power.

2. Press the joint clips (1 EA: front, 2 EA: rear) to the OPEN position.

3. Lift the cover off the product.

4. Remove the UV Unit.

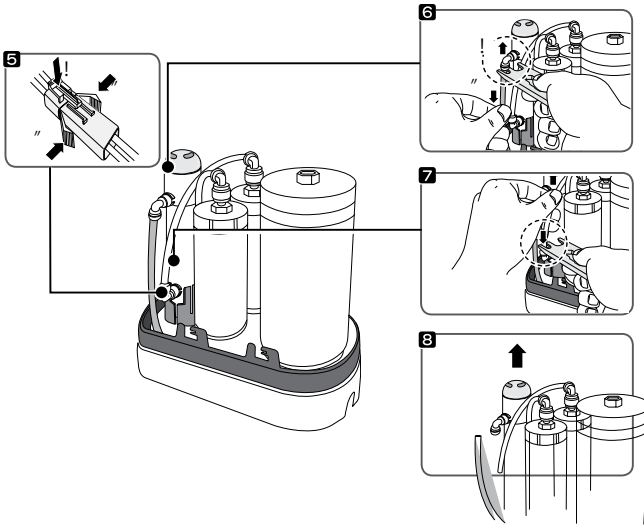
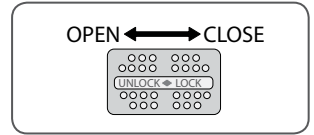
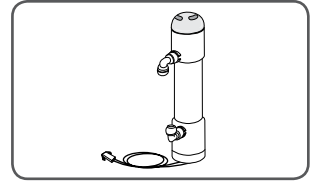

9. To insert the new unit follow the reverse order of the UV Unit removal procedure.

10. After exchanging is complete, close the cover of the product and press three joint clips to the CLOSE position.

11. Connect the power.

12. Reset the LED Display Indicator. Use the Mode Button to select the Filter or Unit that was replaced. Press and hold the Reset Button for 3 seconds to reset the status of the new Filter or Unit to 100%.

13. Flush the system by letting the water run through the whole system for five minutes.

SERVICE AND SPECIFICATIONS

Before Requesting Service

The following troubles can be solved by checkup before requesting Service.

Symptom	Root Cause	Solution
Water is not provided.	Water is shut off or the diverter valve is closed.	Be sure the faucet is on and the diverter valve is open.
	The hoses are kinked.	Correct the hoses to be straightened.
Water leaks from the product.	The filters or units are not fully installed or the tubing is not fully connected.	Close the diverter valve, pull out the power plug. Check to make sure the filters and units are fully installed and the tubing is fully connected.
Water has a strange taste or aroma.	There is an expired filter or unit.	Request filter or unit exchange.
UV Unit is off.	The UV Unit power is disconnected.	Check to be sure the power plug is installed properly.

Product Warranty

**FOR DETAILED WARRANTY INFORMATION,
PLEASE VISIT ROYAL PRESTIGE® ON THE WEB AT
www.royalprestige.com**

For warranty service, send the product to our Service Center:

Hy Cite Corporation
Royal Prestige® Service Center
2115 Pinehurst Drive
Middleton, WI 53562
1-800-279-3373

Genuine Royal Prestige® WQA Certified Replacement Filters and Units may be purchased from your Independent Royal Prestige Representative. For purchase information you may also call the Royal Prestige® Customer Service Center at 1-800-279-3373.

SERVICE AND SPECIFICATIONS

Product Specifications

Product Name		FrescaPure™ Ultra Multistage Water Treatment System
Model Name		WF0601
Water Supply		Tap water
Water Supply Control		Diverter Valve
Rated Service Flow		0.6 gpm
Rated Supply Voltage		AC 110-120V
Power Consumption (Standby)		10W
Manipulation		Open/Close the diverter valve
Operating Temperature		minimum: 4°C/39°F, maximum: 38°C/100°F
Operating Pressure		minimum 20 psi, maximum 150 psi (1.4-10.5 kg/cm2)
Body	Size	254 (width) x 140 (length) x 280 (height) mm
	Weight	3.3 kg
Filtration Unit	Effective filtration	1st: carbon block filter: 4,731 liters (1000 gallons)
		2nd: mineralizer unit: 4,731 liters (1000 gallons)
		3rd: UF membrane filter: 4,731 liters (1000 gallons)
	Filtration material	1st: Pressed carbon block 2nd: Mineral sand, silica sand, zeolite 3rd: Ultra filtration membrane
Exchange Method	Filter/unit exchange	
UV Unit	Type	Filter housing type
	Treatment	UV lamp (Class B UV)
	Power consumption	4W
	Life	approximately. 2,000 hours
	Exchange Method	UV unit exchange
UV Lamp Power Supply	Type	Mechanical (magnetic) ballast
	Input	AC 110-120V
	Output	AC 110-120V



System Tested and Certified by the Water Quality Association according to NSF/ANSI 42, 53 and 55. **See the performance data sheet for specific claims.**

This Class B system or component conforms to NSF/ANSI 55 for the supplemental bactericidal treatment of disinfected public drinking water or other drinking water which has been tested and deemed acceptable for human consumption by the state or local health agency having jurisdiction. The system is only designed to reduce normally occurring non-pathogenic nuisance microorganisms. Class B Systems are not intended for treatment of contaminated water.